

IRONCLAD SPORTS, INC GAMECHANGER

ADJUSTABLE BASKETBALL SYSTEM ASSEMBLY INSTRUCTIONS AND OWNER'S MANUAL

**MODEL: GC-44
GC-55**

⚠ WARNING ⚠

FAILURE TO COMPLY WITH ANY OF THE WARNINGS IN THESE INSTRUCTIONS MAY RESULT IN SERIOUS PERSONAL INJURY.

FAILURE TO COMPLY MAY ALSO RESULT IN PROPERTY DAMAGE. PLEASE HEED ALL WARNINGS AND CAUTIONS TO ENSURE YOUR SAFETY.

DO NOT ATTEMPT TO ASSEMBLE THIS SYSTEM WITHOUT CAREFULLY READING AND FOLLOWING ALL INSTRUCTIONS. BEGIN BY IDENTIFYING AND TAKING INVENTORY OF ALL PARTS USING THE PARTS LIST PROVIDED.

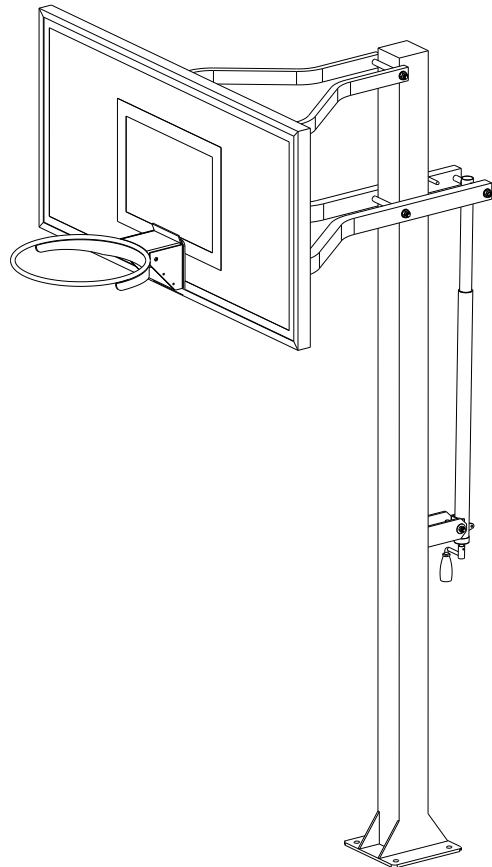

IRONCLAD SPORTS, INC
902 Corey Road, Hutchinson, KS 67501
Tel. : 620-662-2233
www.ironcladsports.com

Keep this instruction manual in case you have to contact the manufacturer for replacement parts.

TOOLS AND MATERIALS REQUIRED FOR ASSEMBLY
(Not Included)

- | | |
|--------------------------|-------------------------------------------------------|
| 1. 2 Adjustable Wrenches | 10. Concrete-1/2 yard or 14-16
Bags, (80 lb. bags) |
| 2. Socket Set | 11. Phillips Head Screwdriver |
| 3. 9/16" Wrench | 12. Electric Drill |
| 4. 3/4" Wrench | 13. Carpenter's Level |
| 5. 15/16" Wrench | 14. A minimum of 2 Ladders |
| 6. 1/2" Wrench | 15. Water Supply |
| 7. Hammer or Mallet | 16. Degreaser |
| 8. Tape Measure | 17. 1/4" Drill Bit |
| 9. Shovel | |

**** A MINIMUM OF SIX ADULTS IS
REQUIRED TO LIFT UNIT INTO PLACE ****

STOP!

BEFORE YOU START

STOP!

- A. Identify and inventory all parts using the checklist boxes in the parts list. Be sure to keep the hardware bags and their contents separate. If any parts are missing call our Customer Service Department (620-662-2233).
- B. Test fit all Bolts by inserting them into the respective hole. If necessary, carefully scrape away any excess powder coating buildup from inside the holes. Do not scrape away all of the powder coating. Bare metal may rust.



SAFETY INSTRUCTIONS



FAILURE TO FOLLOW THESE SAFETY INSTRUCTIONS MAY RESULT IN SERIOUS INJURY OR PROPERTY DAMAGE AND WILL VOID THE WARRANTY. The owner must ensure that all players know and follow these rules to safely operate the system. Proper and complete assembly, use and supervision is essential for proper operation and to reduce the risk of accident or injury. A high probability of serious injury exists if this system is not installed, maintained, or operated properly.

- If using a ladder during assembly, use extreme caution. Follow all warnings and cautions on the ladder carefully.
- 6 people are required to lift the unit into place.
- Before digging, contact the appropriate agency to locate underground power cables, gas, and water lines. Do not install the system within 20 feet of overhead power lines.
- Climate, corrosion, or misuse could result in system failure.
- If technical assistance is required, contact the manufacturer.
- Minimum operational height is 7' 6" to the Rim. Most injuries are caused by misuse and/or failure to follow instructions. Use caution when using the system.

Verify all parts listed on packing list are present prior to installation. Contact our Customer Service at 620-662-2233 for assistance with replacement of any parts missing or damaged.

TEM	QTY	DESCRIPTION
A	1	4.0" x 4.0" Main Post (FOR GC-44 UNIT)
A	1	5.0" x 5.0" Main Post (FOR GC-55 UNIT)
C	2	Lower Extension Arms
D	2	Upper Extension Arms
E	1	Backboard
F	1	Actuator-Height Adjustment Device
G	2	14mm x 245mm Hex Bolts
H	6	14mm Flat Washer
I	3	14mm Lock Nuts
J	1	14mm x 215mm Hex Bolts
K	1	12mm x 115mm Hex Bolts
L	2	12mm Flat Washer
M	1	12mm Lock Nuts
N	4	16mm Anchor J-Bolts
O	1	Anchor Template
P	4	Anchor Rebars
Q	8	Thick Washers
R	8	16mm J-Bolt Hex Nuts
S	4	16mm Flange Nuts
T	4	10mm x 50mm Hex Bolts
U	8	10mm Flat Washer
V	4	10mm Lock Nut
W	4	Plastic Washer

NOTE: Before digging, call to locate any buried utility lines.

NOTE: At rim height 10', distance from the face of backboard to the front of Main Post(A) is 30", Choose the proper location to dig for the concrete footing:

- a. Dig a hole 36" deep and 21" x 21" square. The edge of the hole should be flush with the edge of the playing surface. If you live in an area where heavy frost can occur, it may pose a problem, consult your local building inspector to determine the appropriate hole depth.

NOTE: The hole must be at least 36" deep.

- b. Build a form before pouring the concrete pad, to ensure that the top of the concrete remains straight and square. The form should be placed about 1/2" above the playing surface to allow for water drainage.
- c. Bell out the bottom of the hole.

NOTE: A square hole prevents the rotation of the concrete.

NOTE: The area behind the playing surface must be cleared off by at least 3 feet to enable the user to stand behind the pole to adjust the Rim height.

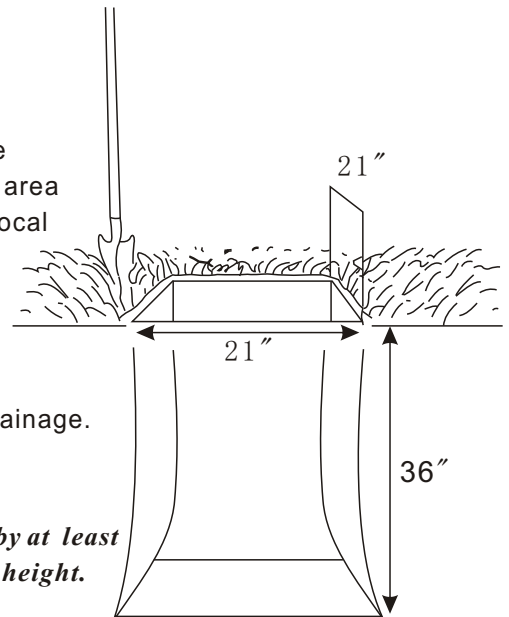

STEP B

- A. Thread a 16mm Hex Nut (M) onto each of the 16mm J-Bolts (N). Securely tighten the Nuts all the way down to the end of the threads.
- B. Slide the threaded end of the J-Bolts through the holes in the Anchor Template (O) and secure each J-Bolt with a 16mm J-Bolt Hex Nuts (R) as shown. Securely tighten all Nuts at this time.

NOTE: Make sure the curved "J" ends of the J-Bolts are oriented in a rectangular pattern, as shown.

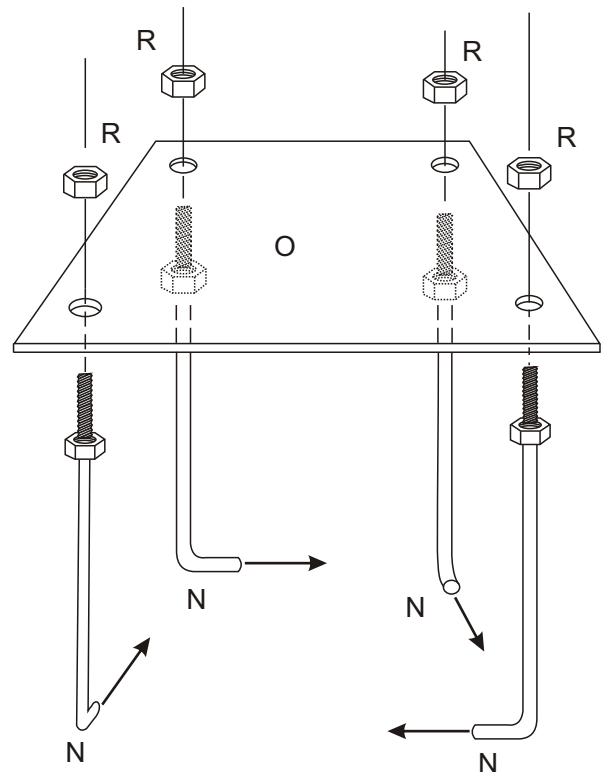
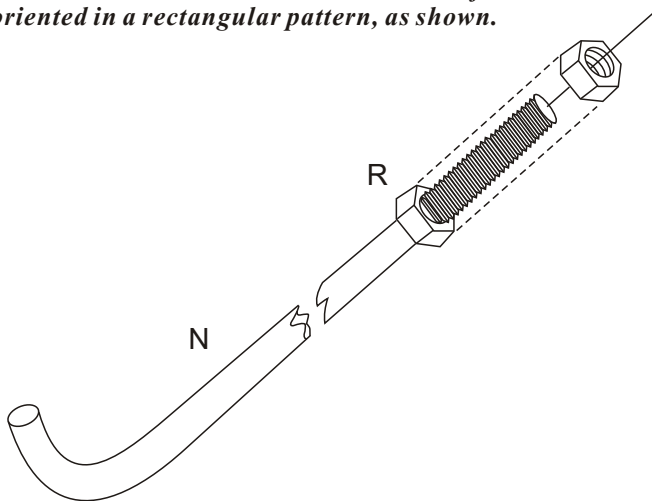

STEP C

- Mix the concrete according to the instructions on the bags. Note that a thicker mix of concrete will dry stronger than a thin mix. Pour the concrete into the hole, stopping approximately 18 inches from the top of the hole.
- Insert the four pieces of Anchor Rebar (P) into the hole, pushing each piece firmly to the bottom of the hole. The four pieces should be arranged in a square approximately 8 inches wide so that each piece of rebar will be positioned next to the J-Bolts when the J-Bolt Template is placed in the cement.
- Finish filling the hole to the top with concrete. The top of the concrete should reach just above the level of the top of the form.

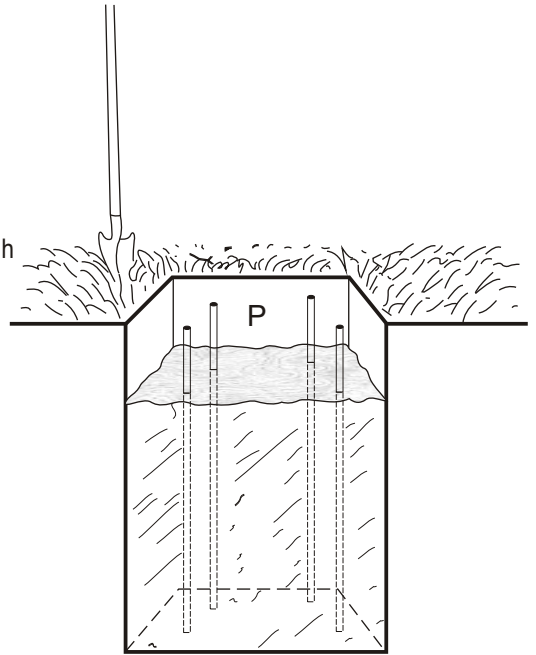

STEP D

- Position the J-Bolt Template (O) over the hole so that it is centered, with the sides of the plate square with the sides of the hole.
- Push the J-Bolts (N) into the concrete until the J-Bolt Template is resting flat against the surface of the concrete.
- Grasp the tops of the J-Bolts and agitate the Template assembly back and forth repeatedly to eliminate any air bubbles in the concrete. Lift the Template slightly above the concrete when agitating. Make sure the Template is resting on the concrete after agitating. Form the concrete into a downward slope away from the Pole to allow water runoff.
- Clean off any concrete that may be on the J-Bolt Template or the exposed portions of the J-Bolts.
- Using a carpenter's level, make sure the Template is square to and level with the playing surface.
- Allow the concrete to cure for a **minimum** of 5-7 days before installing the rest of your basketball system. In cold, wet weather or humid climates, allow additional time for the concrete to cure.

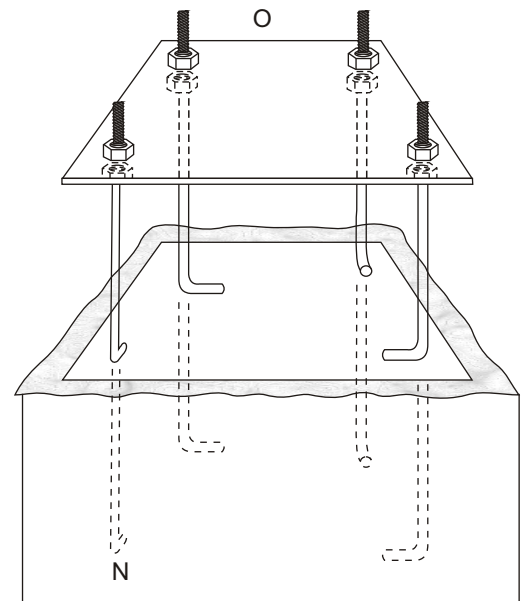

YOU ARE NOW FINISHED WITH THE INITIAL ASSEMBLY STEPS. DO NOT PROCEED WITH THE ASSEMBLY UNTIL THE CONCRETE HAS FULLY CURED. CURING WILL TAKE A MINIMUM OF 72 HOURS. IN HUMID CLIMATES OR WET WEATHER, ALLOW ADDITIONAL TIME FOR THE CONCRETE TO CURE.



WARNING



NEVER USE THE SYSTEM WITHOUT FOLLOWING THE CEMENTING INSTRUCTIONS. FAILURE TO FOLLOW ALL OF THESE INSTRUCTIONS AND WARNINGS COULD LEAD TO SERIOUS PERSONAL INJURY OR PROPERTY DAMAGE AS LISTED ON PAGE ONE.



WARNING



BECAUSE OF THE SIZE AND WEIGHT OF THE SYSTEM, A MINIMUM OF THREE ADULTS ARE REQUIRED FOR THE FOLLOWING STEPS

STEP 1

- A. Slide a 16mm Thick Washer (Q) over each of the J-Bolts(N) as shown in FIGURE 1A.
- B. Place the Main Post(A) over the J-Bolts. Slide a 16mm Thick Washer(Q) and thread a 16mm Flange Nut(S) to each J-bolt. Tighten the Nuts only a few turns onto the J-Bolts as shown in FIGURE 1B.
- C. If the Main Post (A) is not exactly vertical, adjust the 16mm J-Bolt Hex Nuts(R) located under the Post base. Tighten all of the Flange Nuts(S) when Main Post(A) is vertical.

NOTE: Face the Main Post(A) with Actuator Bracket facing away from playing court(as shown in FIGURE 1C).

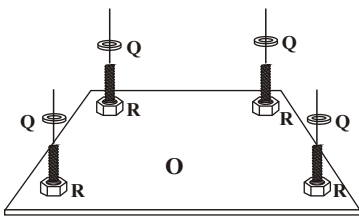

FIGURE 1A

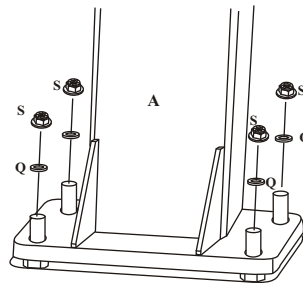

FIGURE 1B

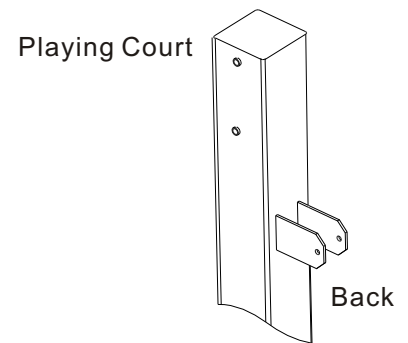
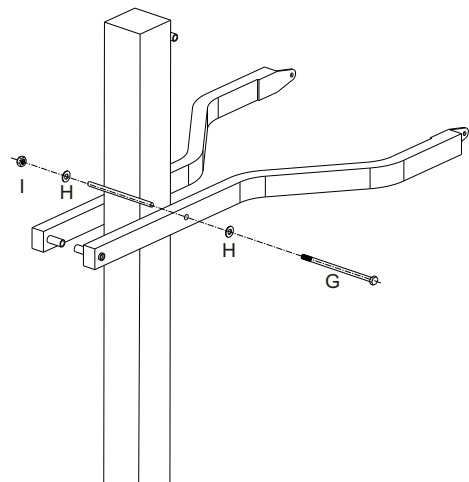

FIGURE 1C

STEP 2

- A. Tight the 2 Lower Extension Arm(C) to Main Post(A) with a 14mm x 240mm Hex Bolt(G), two 14mm Flat Washers(H) and a 14mm Lock Nut(I).



STEP 3

- A. Slide the Actuator(F) to Main Extension Arm(C), Using a 14mm x 245mm Hex Bolt(G), two 14mm Flat Washers(H) and a 1mm Lock Nut(V) at the top. And using a 12mm x 115m Hex Bolt(K), two 12mm Flat Washer(L) a 12mm Lock Nut(M) on bottom to tight the Actuator.

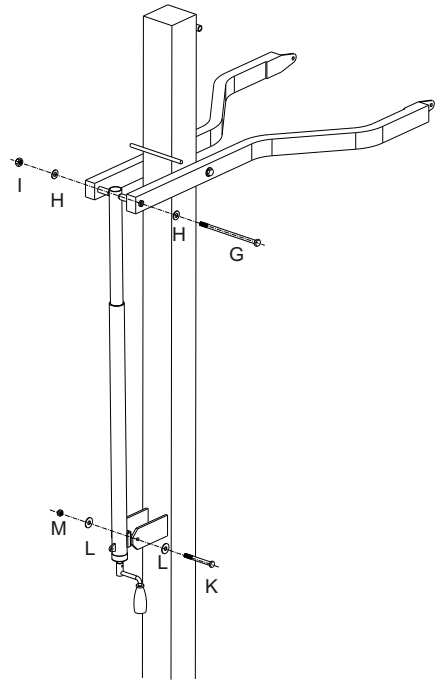

STEP 4

- A. Attach the 2 Upper Extension Arms(D) to Main Post(A) with a 14mm x215mm Hex Bolt(J), two 14mm Flat Washers(H) and a 14mm Lock Nut(I).

CAUTION: Injury may occur if Upper Extension Arms are allowed to fall off Main Extension Arm during assembly.

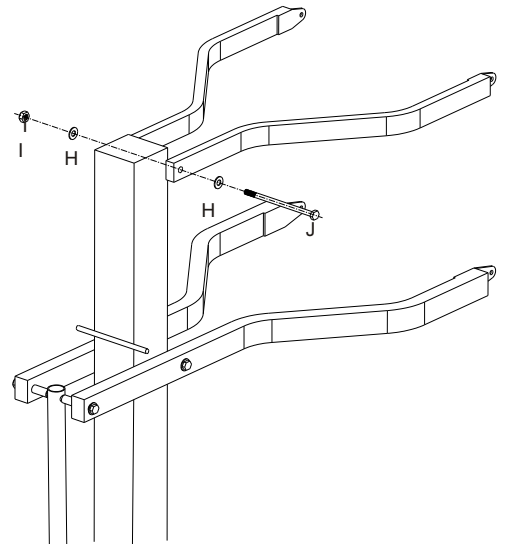

STEP 5

- A. Attach the backboard to Lower Extension Arm(C) by Using a 10mm x 50mm Hex Bolt(T), two 10mm Flat Washers(U), a plastic Washer (W) and a 10mm Lock Nut(V).

NOTE: Put the plastic washer (W) between the extension arm tab and the backboard tubing to prevent paint rub.

- C. Tight other Upper arm by repeat A.

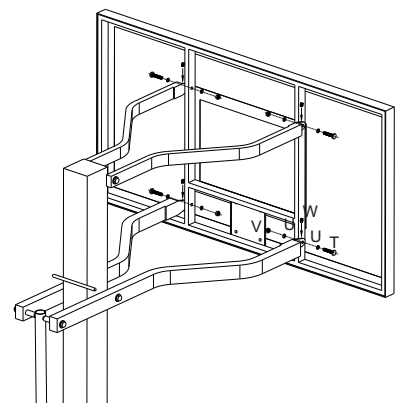

STEP 6

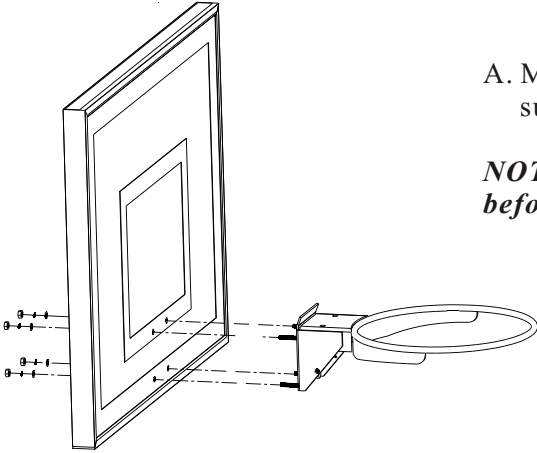

A. Mount the rim to the Backboard by using the hardware supplied in rim box.

NOTE: Use a level to make sure rim is level side to side before tightening nuts.

STEP 7

A. Using a tape measure, crank rim to 10'. Make a pencil mark on the side of the post running along the bottom edge of the lower extension arm. Then crank unit down so rim is at 7.5'. Peel and apply the RIM HEIGHT STICKER to the side of the post, lining up the pencil mark with the 10' mark on the rim height sticker as shown.

